



# SERIE CAIRO 90

Insertable con cristal serigrafiado negro  
Insert with black screen printed glass  
Inserível com vidro serigrafado negro



CAIRO-90D +KIT-CER-90D (Kit Cerámico)  
Opcional: KIT-VER-90D (Kit Vermiculita)  
Facilidad de acceso a la turbina desde la cámara de combustión.  
Ease of access to the turbine from the combustion chamber.  
Facilidade de acesso à turbina a partir da câmara de combustão.



Patas regulables en altura incluida.  
Height adjustable feet included.  
Pés ajustáveis em altura incluída.



Posibilidad de instalación a nivel del suelo.  
(Solo sin KIT-AIRE)  
Possibility of installation at ground level.  
(Only without KIT-AIRE)  
Possibilidade de instalação ao nível do solo.  
(Apenas sem KIT-AIRE)

Regulación del aire frontal, con posibilidad de cerrar completamente y aumentar caudal para canalizar.  
Front air regulation, with possibility to close it completely and increase the ducting flow.  
Regulação de ar da frontal, com a possibilidade de aumentar o fluxo para canalizar.



Elaborado en acero, acabado en pintura anticalórica de 650°C.  
Posibilidad de elegir el interior de la cámara de combustión en vermiculita o cerámica.  
Parrilla en fundición extraíble para facilitar la limpieza.  
Cajón cenicero extraíble para facilitar la limpieza.  
Salidas de canalización micro-perforadas.  
Regulación del aire de combustión primario, secundario y doble combustión.  
Incluye de regalo guante y spray de pintura.

Made of steel and finished in heat resistant paint resistant to 650°C.  
Possibility of choosing the interior of the combustion chamber in vermiculite or ceramic.  
Removable cast iron grill for easy cleaning.  
Removable ash pan for easy cleaning.  
Perforated canalization outlets.  
Regulation of primary and secondary air and double combustion.  
Free glove and spray paint.

Construída em aço, e pintado com tinta anticalórica resistente a 650°C.  
Possibilidade de escolher o interior da câmara de combustão em vermiculite ou cerâmica.  
Grelha em fundição extraível para fácil limpeza.  
Gaveta de cinzas extraível para fácil limpeza.  
Saídas canalizáveis pré-perfuradas.  
Regulação do ar de combustão primário, secundário e dupla combustão.  
Inclui luva e spray de pintura.



## CAIRO-90

**kW** Máx 16  
**kW** 13-4,3  
**m³** 325  
**%** 81  
**flame** 4  
2x120Ø (2)  
Kit vermiculita: 150  
Kit cerámico: 165  
80  
780x260x318

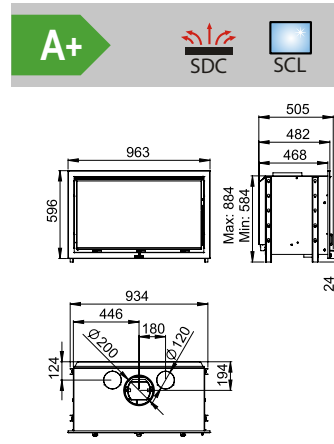

CAIRO-90 +KIT-VER-90F (Kit Vermiculita)  
Opcional: KIT-CER-90F (Kit Cerámico)



## CAIRO-90 E

**kW** Máx 16  
**kW** 13-4,3  
**m³** 325  
**%** 80  
**flame** 4  
2x120Ø (2)  
Kit vermiculita: 150  
Kit cerámico: 165  
80  
780x260x318



CAIRO-90E +KIT-VER-90EI (Kit Vermiculita)  
Opcional: KIT-CER-90EI (Kit Cerámico)

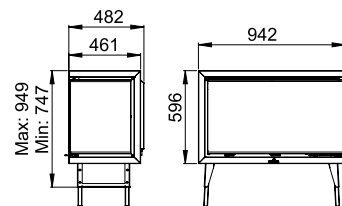

CAIRO-90ED

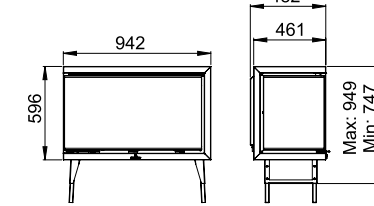

CAIRO-90EI

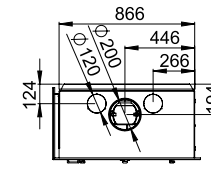
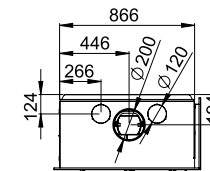

CAIRO-90ED +KIT-VER-90ED (Kit Vermiculita)  
Opcional: KIT-CER-90ED (Kit Cerámico)



## CAIRO-90 D

**kW** Máx 18  
**kW** 14-4,7  
**m³** 350  
**%** 80  
**flame** 3,6  
4x120Ø (4)  
Kit vermiculita: 170  
Kit cerámico: 185  
80  
780x254x416

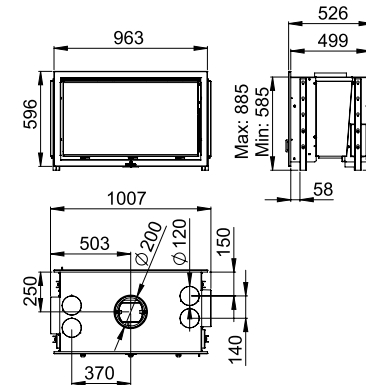

CAIRO-90D +KIT-VER-90D (Kit Vermiculita)  
Opcional: KIT-CER-90D (Kit Cerámico)

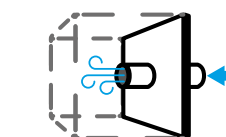

Incluye toma de aire exterior  
-modelo estanco-  
It includes outside air intake  
-hermetic model-  
Inclui tomada de ar exterior  
-modelo estanque-

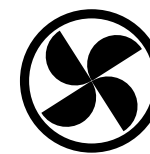

OPCIONAL | OPCIONAL



7 METROS

OPCIONAL: KIT AIRE CAIRO Turbina tangencial + centralita con pantalla táctil de cristal negro, para la regulación manual/automática (mediante sonda de temperatura) de las r.p.m.  
OPTIONAL: CAIRO AIR KIT Tangential turbine + switchboard with black glass touch screen, for manual/automatic regulation (by temperature probe) of the r.p.m.  
OPCIONAL: KIT AIR CAIRO Turbina tangencial + central com tela tátil em vidro preto, para a regulação manual/automática (por sonda de temperatura) das r.p.m.